

Please check the examination details below before entering your candidate information

Candidate surname

Other names

**Pearson Edexcel
International GCSE**

Centre Number

--	--	--	--	--

Candidate Number

--	--	--	--	--

Thursday 7 January 2021

Morning (Time: 2 hours)

Paper Reference **4MA1/1F**

Mathematics A

**Paper 1F
Foundation Tier**



You must have:

Ruler graduated in centimetres and millimetres, protractor, compasses, pen, HB pencil, eraser, calculator. Tracing paper may be used.

Total Marks

Instructions

- Use **black** ink or ball-point pen.
- **Fill in the boxes** at the top of this page with your name, centre number and candidate number.
- Answer **all** questions.
- Without sufficient working, correct answers may be awarded no marks.
- Answer the questions in the spaces provided
– *there may be more space than you need.*
- **Calculators may be used.**
- You must **NOT** write anything on the formulae page.
Anything you write on the formulae page will gain NO credit.

Information

- The total mark for this paper is 100.
- The marks for **each** question are shown in brackets
– *use this as a guide as to how much time to spend on each question.*

Advice

- Read each question carefully before you start to answer it.
- Check your answers if you have time at the end.

Turn over ►

P66295A

©2021 Pearson Education Ltd.

1/1/1





Pearson

International GCSE Mathematics
Formulae sheet – Foundation Tier

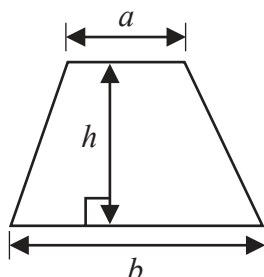
$$\text{Area of trapezium} = \frac{1}{2}(a + b)h$$

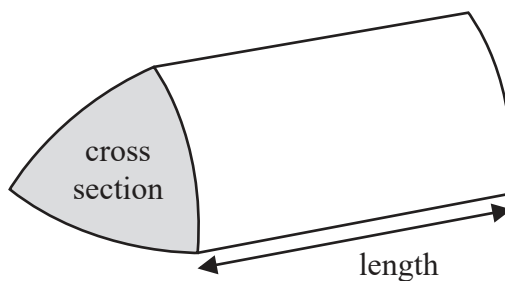

$$\text{Volume of prism} = \text{area of cross section} \times \text{length}$$



$$\text{Volume of cylinder} = \pi r^2 h$$

$$\text{Curved surface area of cylinder} = 2\pi r h$$

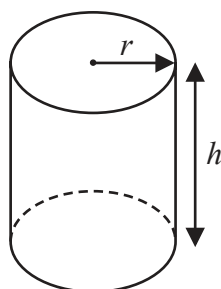

DO NOT WRITE IN THIS AREA

DO NOT WRITE IN THIS AREA

DO NOT WRITE IN THIS AREA



Answer ALL TWENTY SIX questions.

Write your answers in the spaces provided.

You must write down all the stages in your working.

- 1 The table shows the height, in metres, of each of seven volcanoes.

Volcano	Height (metres)
Acamarachi	6046
Bazman	3490
Dona Juana	4150
Kamen	4585
Mount Ararat	5137
Ojos del Salado	6893
Semeru	3676

- (a) Which of these volcanoes has the greatest height?

.....
(1)

- (b) Write down the value of the 8 in the number 4585

.....
(1)

- (c) Write the number 6046 in words.

.....
(1)

- (d) Write the number 5137 correct to the nearest hundred.

.....
(1)

- (e) Work out the difference in the height of the Acamarachi volcano and the height of the Semeru volcano.

..... metres
(1)

(Total for Question 1 is 5 marks)



2 Sandeep is designing some 3-sided spinners.

He is going to spin each spinner once.

- (a) (i) Write a different number on each dotted line so that when the spinner is spun it is **impossible** that the spinner will land on a number greater than 9

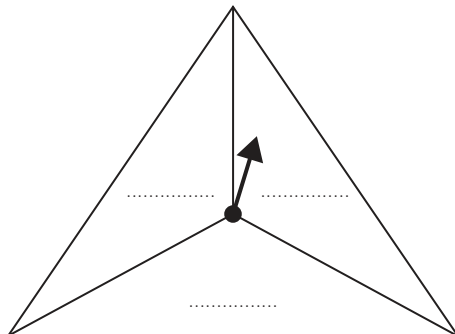

(1)

- (ii) Write a different number on each dotted line so that when the spinner is spun it is **certain** that the spinner will land on a multiple of 10

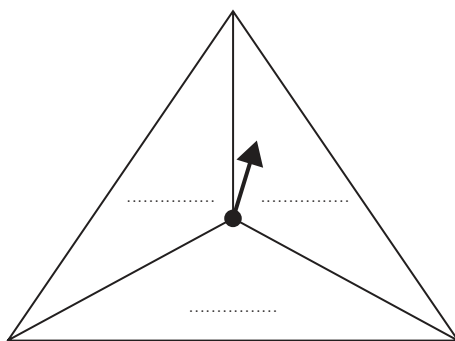

(1)

The likelihood of an outcome is **evens**.

- (b) On the probability scale, mark with a cross (X) the probability of this outcome.

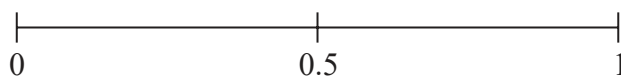

(1)

(Total for Question 2 is 3 marks)



3 Amir is going on holiday.

He weighs his suitcase on the weighing scales at the airport.
The reading on the scale gives the weight of Amir's suitcase.

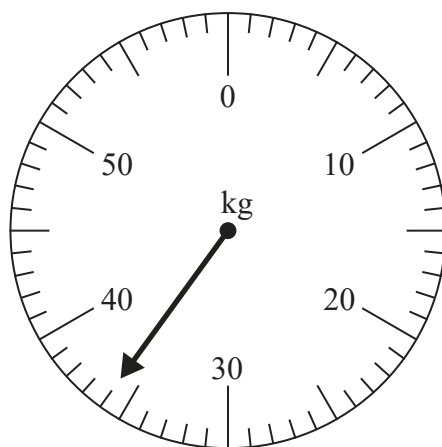

An excess luggage charge has to be paid when the weight of a suitcase is greater than 25 kg.

This charge is 7.45 euros for each kilogram over the 25 kg limit.

Work out the excess luggage charge that Amir has to pay.

..... euros

(Total for Question 3 is 3 marks)



4 (a) Write 0.57 as a fraction.

.....
(1)

(b) Write 0.02 as a percentage.

.....%

(1)

(c) Write $\frac{72}{84}$ as a fraction in its simplest form.

.....
(1)

(d) Write $\frac{22}{5}$ as a mixed number.

.....
(1)

(e) Work out $\frac{1}{8}$ of 624

.....
(1)

(Total for Question 4 is 5 marks)



DO NOT WRITE IN THIS AREA

DO NOT WRITE IN THIS AREA

DO NOT WRITE IN THIS AREA

5 A sequence of shapes is made by shading squares on a square grid.

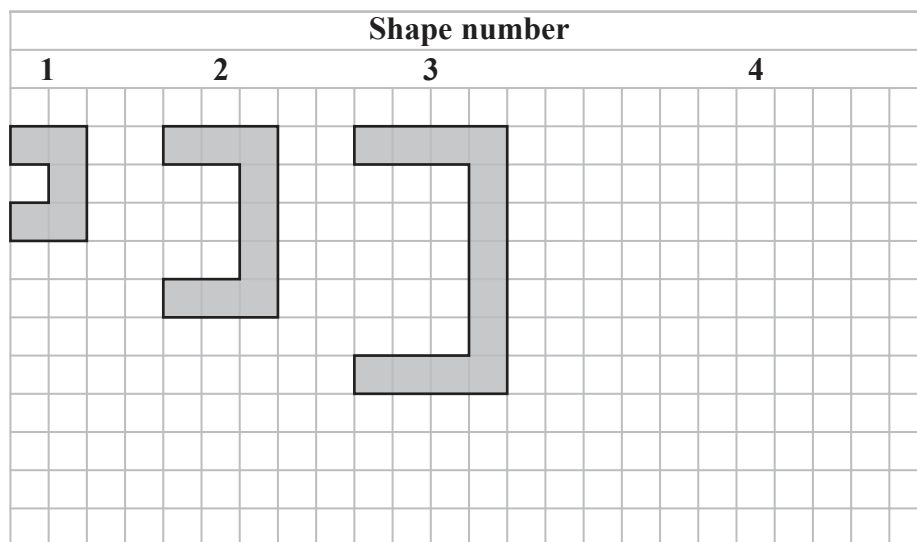

(a) On the grid, draw Shape number 4

(1)

(b) Complete the table.

Shape number	1	2	3	4	5
Number of shaded squares	5	9	13		

(1)

(c) Find the number of shaded squares in Shape number 8

.....
(1)

(d) Explain why no shape in the sequence is made by shading exactly 50 squares.

.....
.....
(1)

(Total for Question 5 is 4 marks)



6 Nav makes bracelets using cord.

Nav has a 6 metre length of cord.

Each bracelet needs 17.5 cm of cord.

Work out the greatest number of bracelets that Nav can make.

.....
(Total for Question 6 is 3 marks)

7 (a) Simplify $10x + 4y + 3x - 6y$

.....
(2)

(b) Solve $2n + 5 = 16$

$n =$
(2)

(Total for Question 7 is 4 marks)



- 8 The two-way table shows some information about the 60 noodle meals eaten in a noodle bar by each of 60 people last Friday.

Type of noodle

	Ramen	Soba	Udon	Total
Boiled	18			31
Fried		12	7	
Total			15	60

- (a) Complete the two-way table.

(3)

One of the 60 people is selected at random.

- (b) Write down the probability that this person ate Fried Udon noodles.

.....
(1)

(Total for Question 8 is 4 marks)



- 9 The diagram shows quadrilateral $ABCD$ and isosceles triangle ADE , where $AE = AD$.

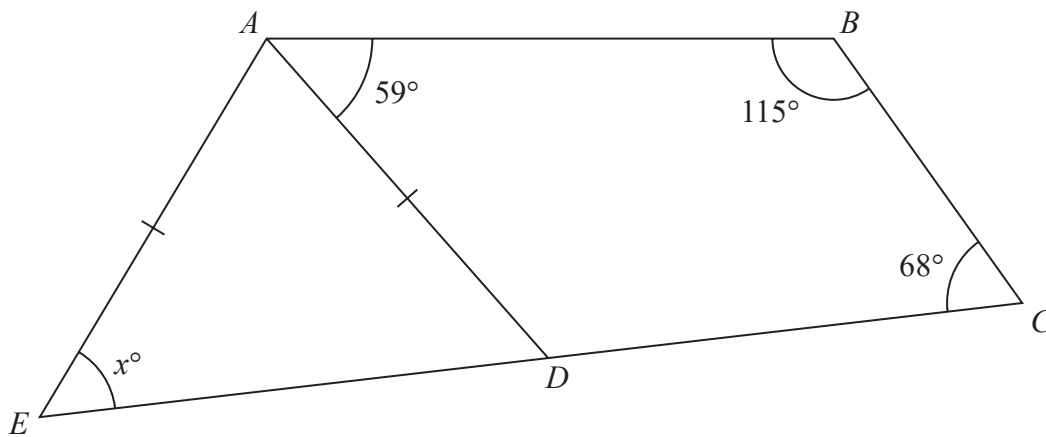

EDC is a straight line.

Work out the value of x .

Give a reason for each stage of your working.

$x = \dots\dots\dots$

(Total for Question 9 is 4 marks)

DO NOT WRITE IN THIS AREA

DO NOT WRITE IN THIS AREA

DO NOT WRITE IN THIS AREA



DO NOT WRITE IN THIS AREA

DO NOT WRITE IN THIS AREA

DO NOT WRITE IN THIS AREA

10 In Koko's shop

5 chocolate bars cost \$5.75

2 chocolate bars and 3 packets of sweets cost \$7.85

Work out the cost of one packet of sweets.

\$.....

(Total for Question 10 is 3 marks)

11 Akiko travelled from London to Tokyo by plane.

The plane left London at 1840 on Friday.

The plane arrived in Tokyo the next day, at 0625 London time.

How long did the flight take?

Give your answer in hours and minutes.

..... hours minutes

(Total for Question 11 is 2 marks)



P 6 6 2 9 5 A 0 1 1 2 4

12 (a) Expand $x(4 - x)$

.....
(1)

$$t = ab - c$$

$$a = 1.5 \quad b = 2.4 \quad c = -5.6$$

(b) Work out the value of t .

$$t = \text{.....}$$

(2)

(c) Make d the subject of $y = dx - e$

.....
(2)

(Total for Question 12 is 5 marks)

DO NOT WRITE IN THIS AREA

DO NOT WRITE IN THIS AREA

DO NOT WRITE IN THIS AREA



DO NOT WRITE IN THIS AREA

DO NOT WRITE IN THIS AREA

DO NOT WRITE IN THIS AREA

13 (a) Express 180 as a percentage of 750

.....%
(2)

Zaina has booked a singer for a show.
The singer will get 94% of the total money from the ticket sales.

The cost of each ticket for the show is 32.50 dirhams.
Zaina sells 180 tickets.

(b) Work out the amount of money the singer will get.

..... dirhams
(3)

(Total for Question 13 is 5 marks)



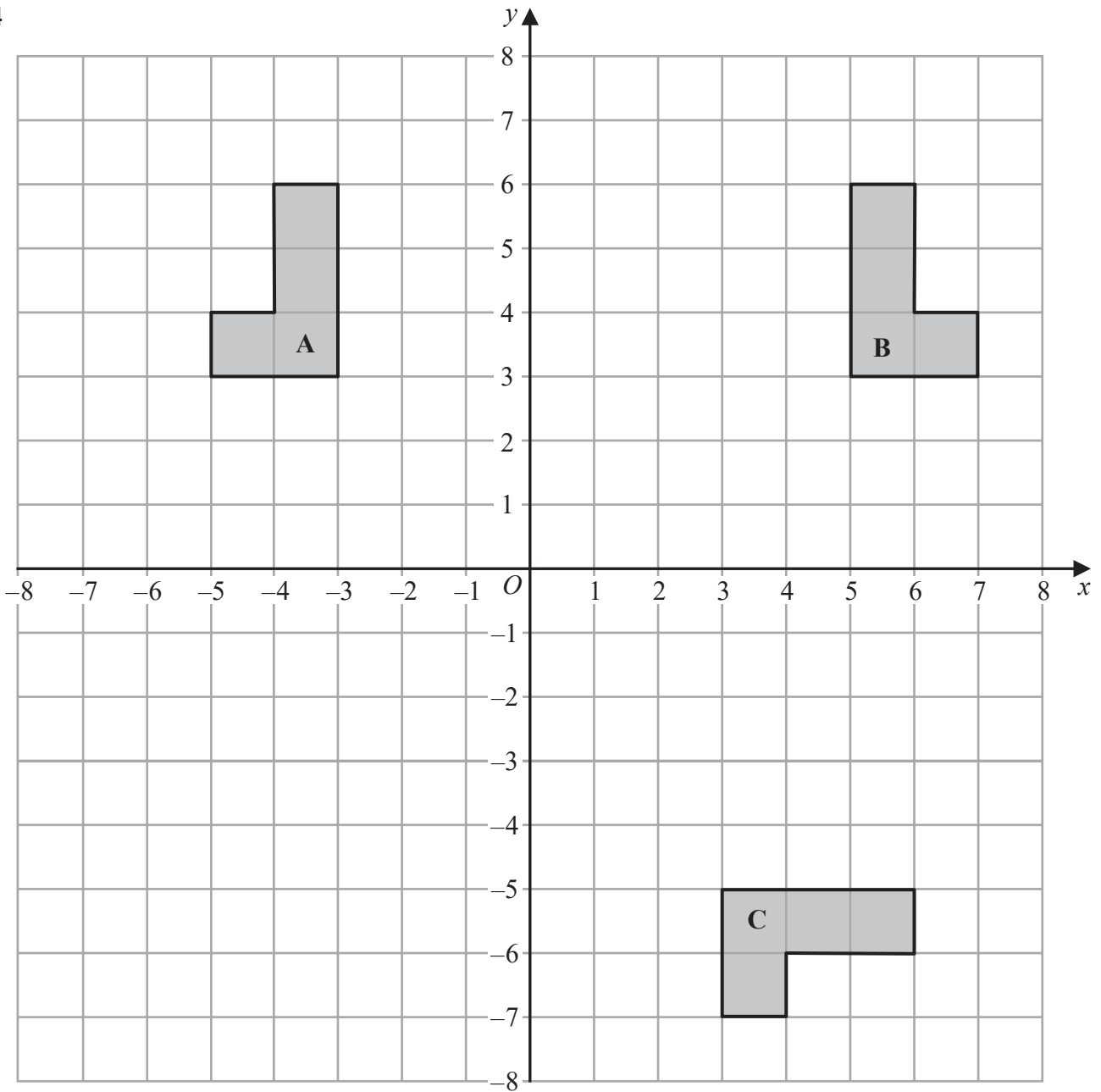

(a) Describe fully the single transformation that maps shape **A** onto shape **B**.

(2)

(b) Describe fully the single transformation that maps shape **B** onto shape **C**.

(3)

(Total for Question 14 is 5 marks)



- 15 A bag contains 30 coloured counters.
The table gives the number of counters of each colour.

Colour	Red	Green	Yellow	Blue
Number of counters	7	13	4	6

One of the counters is taken at random from the bag.

- (a) Write down the probability that this counter is green.

.....
(1)

- (b) Write down the probability that this counter is **not** red.

.....
(2)

(Total for Question 15 is 3 marks)

- 16 Show that $\frac{5}{6} - \frac{3}{8} = \frac{11}{24}$

(Total for Question 16 is 2 marks)



17 Pieter owns a currency conversion shop.

Last Monday, Pieter changed a total of 20 160 rand into a number of different currencies.

He changed $\frac{3}{10}$ of the 20 160 rand into euros.

He changed the rest of the rands into dollars, rupees and francs in the ratios 9:5:2

Pieter changed more rands into dollars than he changed into francs.

Work out how many more.

..... rand

(Total for Question 17 is 4 marks)



- 18 The table gives information about the speeds, in kilometres per hour, of 80 motorbikes as each pass under a bridge.

Speed (s kilometres per hour)	Frequency
$40 < s \leq 50$	10
$50 < s \leq 60$	16
$60 < s \leq 70$	19
$70 < s \leq 80$	23
$80 < s \leq 90$	12

- (a) Write down the modal class.

.....
(1)

- (b) Work out an estimate for the mean speed of the motorbikes as they pass under the bridge.
Give your answer correct to 3 significant figures.

..... kilometres per hour
(4)

(Total for Question 18 is 5 marks)



19 The diagram shows a container for water in the shape of a prism.

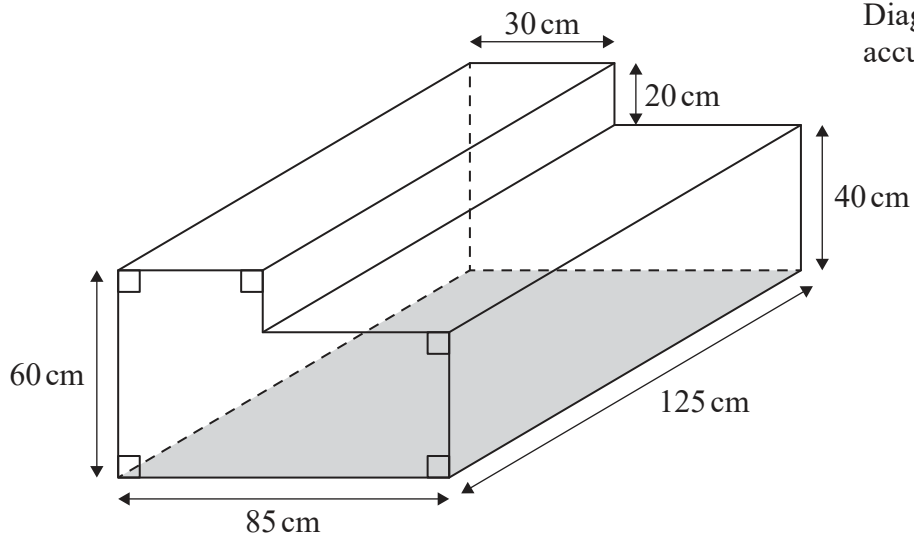

Diagram NOT accurately drawn

The rectangular base of the prism, shown shaded in the diagram, is horizontal. The container is completely full of water.

Tuah is going to use a pump to empty the water from the container so that the volume of water in the container decreases at a constant rate.

The pump starts to empty water from the container at 10 30 and at 12 00 the water level in the container has dropped by 20 cm.

Find the time at which all the water has been pumped out of the container.

(Total for Question 19 is 4 marks)



20 $\mathcal{E} = \{20, 21, 22, 23, 24, 25, 26, 27, 28, 29\}$

$$A = \{\text{odd numbers}\}$$

$$B = \{\text{multiples of 3}\}$$

List the members of the set

(i) $A \cap B$

.....
(1)

(ii) $A \cup B$

.....
(1)

(Total for Question 20 is 2 marks)



21 (a) Factorise fully $15y^4 + 20uy^3$

.....
(2)

(b) Solve $4 - 3x = \frac{5 - 8x}{4}$

Show clear algebraic working.

$x =$
(3)

(Total for Question 21 is 5 marks)

22 (a) Write 2 840 000 000 in standard form.

.....
(1)

(b) Write 2.5×10^{-4} as an ordinary number.

.....
(1)

(Total for Question 22 is 2 marks)



23 Chen invests 40 000 yuan in a fixed-term bond for 3 years.

The fixed-term bond pays compound interest at a rate of 3.5% each year.

- (a) Work out the value of Chen's investment at the end of 3 years.
Give your answer to the nearest yuan.

..... yuan
(3)

Wang invested P yuan.

The value of his investment decreased by 6.5% each year.

At the end of the first year, the value of Wang's investment was 30 481 yuan.

- (b) Work out the value of P .

$P =$
(3)

(Total for Question 23 is 6 marks)



24 The region, shown shaded in the diagram, is a path.

Diagram **NOT** accurately drawn

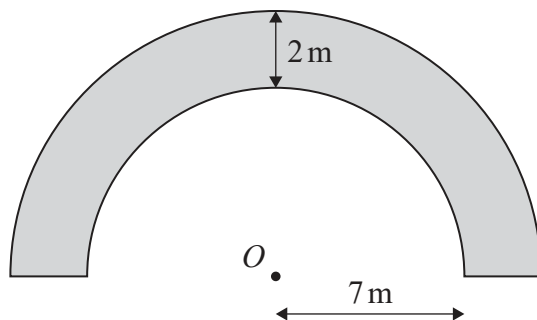

The boundary of the path is formed by two semicircles, with the same centre O , and two straight lines.

The inner semicircle has a radius of 7 metres.

The path has a width of 2 metres.

Work out the perimeter of the path.

Give your answer correct to one decimal place.

..... m

(Total for Question 24 is 3 marks)

DO NOT WRITE IN THIS AREA

DO NOT WRITE IN THIS AREA

DO NOT WRITE IN THIS AREA



DO NOT WRITE IN THIS AREA

DO NOT WRITE IN THIS AREA

DO NOT WRITE IN THIS AREA

25 (a) Simplify $(2x^3y^5)^4$

.....
(2)

(b) (i) Factorise $x^2 + 5x - 36$

.....
(2)

(ii) Hence, solve $x^2 + 5x - 36 = 0$

.....
(1)

(Total for Question 25 is 5 marks)



P 6 6 2 9 5 A 0 2 3 2 4

26 Here is isosceles triangle ABC .

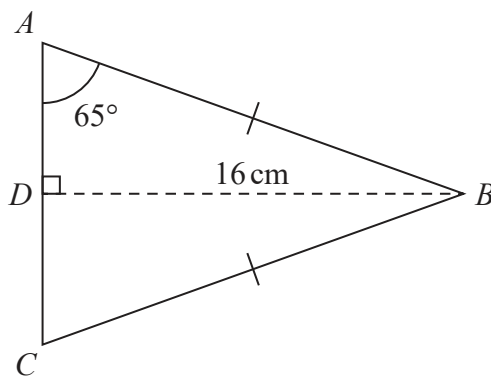

Diagram **NOT** accurately drawn

D is the midpoint of AC and $DB = 16$ cm.

Angle $DAB = 65^\circ$

Work out the perimeter of triangle ABC .
Give your answer correct to one decimal place.

..... cm

(Total for Question 26 is 4 marks)

TOTAL FOR PAPER IS 100 MARKS

